



WLG

2010-02-26 Updated DCH

-  Automatic valve
-  Manual valve
-  Critical orifice
- mfm Mass flow meter
- mfc Mass flow controller

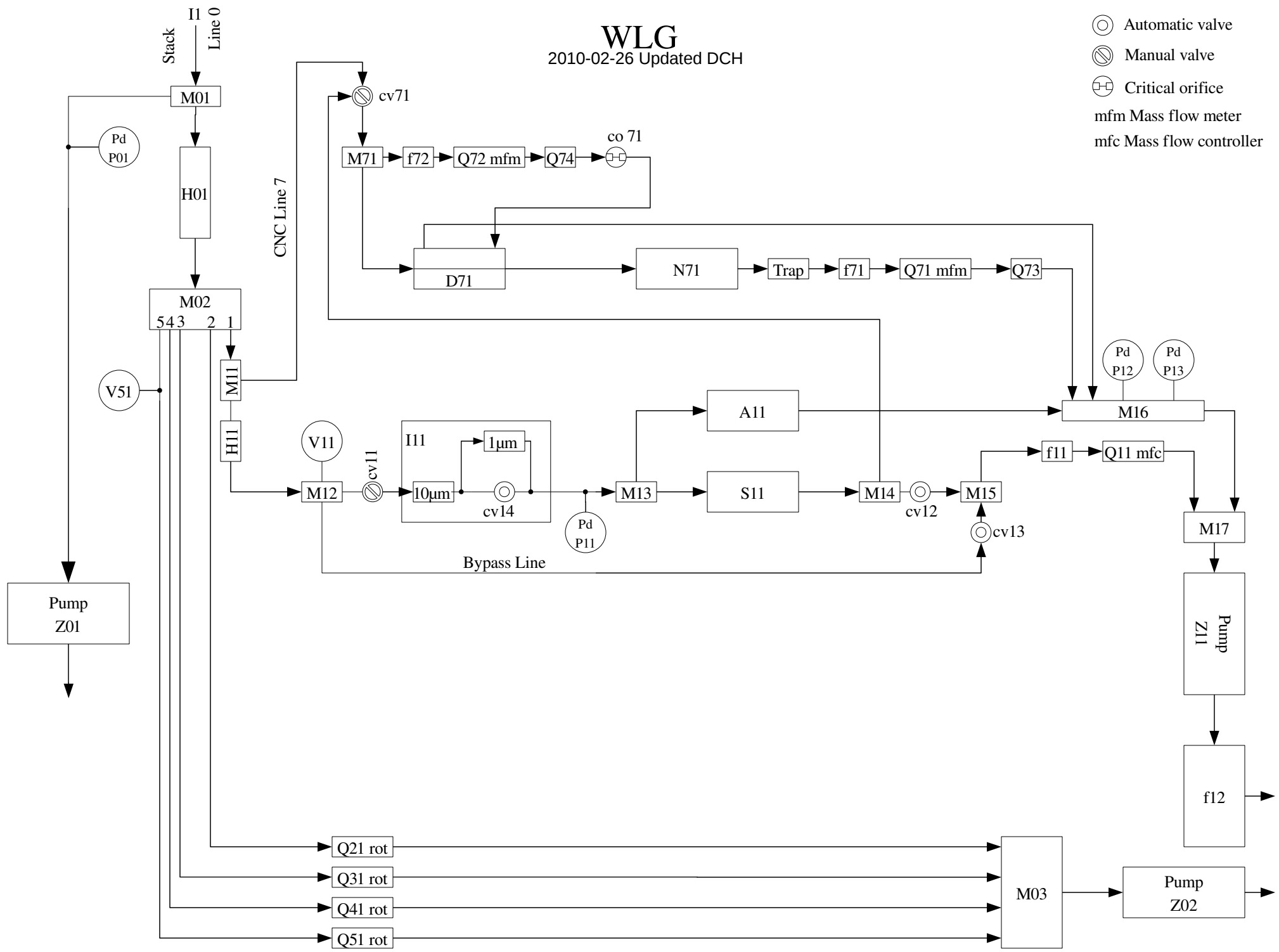

Bap_B_3W -> BaS_A11
Bap_G -> BaO_A11
Bap_G_3W -> BaL_A11
Bap_R_3W -> BaC_A11
CN_control -> N_N61
dP_neph_imp_hPa -> Pd_P11
dp_Pitot_hPa -> Pd_P01
dP_spare2 -> Pd_P12
Flags -> F_aer
P_refNeph -> P_S11
Q_analyzer_lpm -> Q_Q11
Q_CN_lpm -> Q_Q61
Q_CNdrier_lpm -> Q_Q62
RefBbsp_B -> BbsB_S11
RefBbsp_G -> BbsG_S11
RefBbsp_R -> BbsR_S11
RefBsp_B -> BsB_S11
RefBsp_G -> BsG_S11
RefBsp_R -> BsR_S11
RH_Ambient -> U_V01
RH_Inlet -> U_V51
RH_refInlet -> Uu_S11
RH_refNeph -> U_S11
T_Ambient -> T_V01
T_Inlet -> T_V51
T_pumpbox_degC -> T_V02
T_refInlet -> Tu_S11
T_refNeph -> T_S11
T_uMAC_degC -> T_X1
V_uMAC_V -> V_X1
WD -> Wd_X3
WS -> Ws_X3

BaC_A11 -> Bap_R_3W
BaL_A11 -> Bap_G_3W
BaO_A11 -> Bap_G
BaS_A11 -> Bap_B_3W
BbsB_S11 -> RefBbsp_B
BbsG_S11 -> RefBbsp_G
BbsR_S11 -> RefBbsp_R
BsB_S11 -> RefBsp_B
BsG_S11 -> RefBsp_G
BsR_S11 -> RefBsp_R
F_aer -> Flags
N_N61 -> CN_control
P_S11 -> P_refNeph
Pd_P01 -> dp_Pitot_hPa
Pd_P11 -> dP_neph_imp_hPa
Pd_P12 -> dP_spare2
Q_Q11 -> Q_analyzer_lpm
Q_Q61 -> Q_CN_lpm
Q_Q62 -> Q_CNdrier_lpm
T_S11 -> T_refNeph
T_V01 -> T_Ambient
T_V02 -> T_pumpbox_degC
T_V51 -> T_Inlet
T_X1 -> T_uMAC_degC
Tu_S11 -> T_refInlet
U_S11 -> RH_refNeph
U_V01 -> RH_Ambient
U_V51 -> RH_Inlet
Uu_S11 -> RH_refInlet
V_X1 -> V_uMAC_V
Wd_X3 -> WD
Ws_X3 -> WS