

Procedure for maintenance to filter wheel #3 in a Mk IV Brewer spectrophotometer

**National Ultra Violet Monitoring Center
Department of Physics and Astronomy
University of Georgia
Athens, GA 30602**



**Document 10
Revision A**

**Prepared by Dr M.G. Kimlin and T.E. Taylor
Last updated October 30, 2002**



Introduction

Brewer Mk IV spectrophotometers are equipped with several rotating filter wheels which allow selection of different filters for various instrument scans. On occasion the mechanical components of the filter wheels encounter difficulties and maintenance work must be performed to correct these problems. In particular, filter wheel #3 can present trouble since it contains a hygroscopic NiSO₄ filter and is enclosed in a sealed housing. When the NiSO₄ filter absorbs moisture its optical properties are compromised, usually resulting in a decrease in transmittance. This leads to a decrease in the overall sensitivity of the Brewer in the region where the NiSO₄ filter is used (2865-3250 A for a full spectrum UV scan). Changes to the filter transmittance also compromise the ozone measurements taken by the instrument.

Erratic R5 and R6 ratios recorded in the instrument's Sloavg file are symptomatic of a problem with the operation of FW#3. The results of filter wheel reset tests will help in determining if FW#3 is being found in the correct position. Decaying NiSO₄ transmission can be observed in the bi-weekly 50W lamp scans and in the standard lamp intensities as well as spectral response calibrations.

Equipment

Mk IV Brewer spectrophotometer
Hex wrench set (English sizes)
Flat head screw driver (small)
Wire snips
Replacement NiSO₄ filter (if necessary)

Purpose

This Standard Operating Procedure (SOP) outlines the NUVMC technique for checking the operation of filter wheel #3 in a Mk IV Brewer and removing and replacing the NiSO₄ filter if necessary.

Procedure

1. If the Brewer is still running in schedule exit the schedule by pressing the Home key when the message "Press Home to abort schedule" appears on the computer screen.
2. Turn on the computer printer and give the command "PN" at the Brewer Home screen command line to allow the computer to write information to the printer.

3. Give the command "O3" at the Home screen command line to set the Brewer in the Ozone mode.
4. To determine if the FW#3 is operating properly perform a filter wheel reset by giving the command FR at the Brewer Home screen command line. This routine zeroes the micrometer and then zeroes FW#3. Note the FW#3 position on the computer screen or the printout. The proper FW#3 position is step -242. If FW#3 was not in the correct position the result will deviate from this number. Perform two more FR tests and note the results.
5. If it is determined that the FW#3 is not operating properly or if the NiSO₄ filter is to be replaced, perform an initial spectral response calibration on the instrument before performing any work to FW#3. The NUVMC has an SOP for performing a calibration. If the NiSO₄ filter is to be replaced a spectral response temperature dependence calibration should be performed also. An SOP for this procedure, both in the laboratory and in the field, has been written by the NUVMC.
6. If it is not possible to perform a spectral response calibration, perform 50W lamp scans per the normal bi-weekly procedure. Run three lamps instead of the usual two to provide more data.
7. Move the Brewer to a clean, indoor environment with ample space to work.
8. Connect the AC power and data cable and initialize communication between the Brewer and computer.
9. Once it has been determined that the system is able to communicate, kill the power to the Brewer and disconnect the AC power cable.
10. Place a protective cover on the quartz dome on the top of the Brewer outer cover.
11. Remove the Brewer outer cover by loosening the four latches and lifting the cover up.
12. Locate the FW#3 housing. It is sandwiched between the spectrometers exit slits/shutter and the photomultiplier tube (PMT). Refer to Figure 1. Note the figure shows a schematic of a single electronic board instrument. The layout of a multi board instrument is similar. Locate the stepper motor for FW#3 which is attached to the FW#3 housing to the left of the PMT tube. On top of the FW#3 housing there is a small hatch secured by two 3/32" hex head screws which allows for visual inspection of the

FW#3. Just above the FW#3 view hatch there is a ribbon cable which connects to the shutter stepper motor which is hidden from view inside the black spectrometer box. There is another ribbon cable connected to a bulkhead connector located to the right side of the PMT. This is the cable that controls FW#3. There is a multi-colored bunch of wires from the bulkhead connector to the FW#3 stepper motor.

13. Remove the connectors for the shutter motor by loosening the two 3/32" hex bolts.
14. Loosen the two 3/32" hex head bolts that secure the FW#3 hatch. It is unnecessary to remove the screws completely. Swivel the hatch to expose the internals of the FW#3 housing. Using a flashlight to illuminate FW#3, notice the black hash marks between the teeth of the cogs, similar to those on FW#1 and #2.
15. At the Brewer Home screen command line give the "TT" command to move to teletype mode. This mode of operation allows direct control of the Brewer's various motors. Using Table 1 as a reference, move FW#3 to various positions, noting via the hash marks if the wheel actually goes to the correct place. For example, typing "M,6,50" in TT mode should move FW#3 to position 1.
16. Give the command "M,6,0:M,6,256:a". This will rotate FW#3 continually from position 1 to 4 to 1. Observe if the FW#3 moves smoothly and does not bind. There should be a rhythm to the rotation that will be interrupted intermittently if there is a binding problem. Abort the command by pressing the "Home" key.
17. If FW#3 appears to be rotating erratically use a small screwdriver or similar tool inserted into the FW housing to gently rotate FW#3. Pay attention for any rough or uneven movement that may indicate problems with bearings or with the wheel getting hung up on something inside the housing.
18. If it is determined that the FW#3 is moving to the correct position each time then there is most likely no mechanical difficulty with the stepper motor or filter wheel. Close the FW#3 housing hatch and tighten down the two screws.
19. Any problem that may have been noted before in the Brewer diagnostic files could be intermittent. This could be due to a bad connection between the controlling I/O board and the stepper motor or between the bulkhead wires and the stepper motor. All connections should be inspected carefully

- for signs of damage or looseness, especially pin crimps on the wires from the bulkhead connector to the stepper motor. The FW#3 ribbon cable should be replaced.
20. If it is obvious that FW#3 is not moving as commanded the problem could be caused by any combination of faulty/intermittent cable/wire connections, a faulty I/O board, faulty stepper motor or difficulties with the mechanical integrity of the FW#3 assembly.
 21. The condition of FW#3's electronic board and ribbon cable can be checked by using them to run FW#2. Disconnect the ribbon cable connector from FW#3 and FW#2. Connect the FW#3 ribbon cable to the 25-pin connector for the FW#2 stepper motor. Refer to Table 2 for FW board positions and pin-jumper numbers.
 22. Move FW#2 using the teletype mode of the Brewer and referring to Table 1 for the appropriate command string to operate FW#3. Remember that FW#2 is now being controlled by the I/O board for FW#3. Therefore commands appropriate to move FW#3 must be given.
 23. Monitor the position of FW#2 as each string of commands is given and verify that the FW moves to the correct position as indicated by the hash marks. If the problem is in the I/O board and/or the ribbon cable then the same results should be obtained by this test as were observed with FW#3. If the same behavior is observed the I/O board and the ribbon cable should be swapped out with spare components. If FW#2 behaves in a normal manner then the problem probably lies in the FW#3 stepper motor or the mechanical assembly of FW#3.
 24. If it is determined that there is a problem with the rotation of the filter wheel within the housing or if the NiSO₄ filter is to be replaced, The FW#3 housing will have to be removed from the Brewer.
 25. Disconnect all the electronic ribbon cables from the card rack. The connectors should be labeled in black ink corresponding to the board and jumper to which they are connected.
 26. Remove the two 3/32 inch hex bolts that secure the back card rack feet to the bottom of the Brewer case. These screws are accessed from underneath the instrument.
 27. Remove the two 9/64 inch hex bolts securing the front card rack feet to the Brewer base.

28. Remove the card rack from inside the Brewer.
29. If there are wires fastened to the side of the rack by cable ties, the ties may be snipped so that the card rack can be moved.
30. Disconnect the FW#3 ribbon cable connector from the FW#3 housing via the two hex head bolts.
31. Disconnect the high voltage (HV) cable from the base of the photomultiplier tube (PMT) by twisting the BNC connector off the mate.
32. Remove the 9 pin signal line from the PMT base by loosening the two flat head screws on the 9-pin connector.
33. Remove the white face plate covering the foreoptics tube by removing the two 3/32 inch hex screws fastening the plate to the Brewer chassis at the spectrometer. Loosen the single 3/32 hex screw on the side of the face plate near the zenith prism. Lift the plate off and set it aside.
34. Remove the thermister that is inserted into the top of the FW#3 housing. Usually an epoxy is used to seal it.
35. Remove the four 5/32 inch hex head bolts holding FW#3 housing to the Brewer chassis. Remove the FW#3 housing from the Brewer with the PMT attached.
36. Cover the spectrometer exit slit with paper to protect it. Wipe any dirt or dust out of the chassis.
37. Loosen the six 9/64 inch hex head bolts that secure PMT to the FW#3 housing. Remove the PMT from the housing in a reduced light area and cover the open end of the PMT with cloth. Place the PMT in a padded box or other storage vessel and avoid exposing it to light.
38. Remove the white plastic insulating spacer from the FW#3 housing.
39. Remove four 3/32 inch hex head bolts that hold the two halves of FW#3 together.
40. Note the construction of the FW#3 system; the steel FW shaft inserts into the side of the housing containing the focusing lens, a white nylon spacer rides on the shaft, the FW rides on top of the spacer, one crushed washer with the flat side facing the FW rests on top of the FW (nylon spacers may

be used instead of a crushed washer in order to adjust the position of the FW within the housing).

41. Each filter is held in a filter holder with three dabs of epoxy. The filter holders are secured to the wheel via two hex head bolts. To change a filter the holder should be removed from the wheel. The epoxy can be scraped away and the filter can then be removed from the holder. Be sure the replacement filter is sitting flush against the holder when applying the epoxy. Use low out gassing epoxy. The epoxy should be allowed to fully cure before the filter wheel assembly is reassembled.
42. Reassemble the housing and replace the two rubber o-rings which seal the housing; one large o-ring between FW housing halves and one small o-ring below the FW view hatch.
43. Once the FW halves are mated back together, rotate the FW with a small screw driver through the viewing hatch to test for smoothness. Be sure the optical flag mounted on the wheel does not bind on the optical diode. The thin nylon spacers on the FW shaft can be added or removed as needed to get the spacing correct.
44. Replace the white plastic insulating spacer with the flat side facing the FW housing.
45. Replace the o-ring between PMT and the FW housing and place the PMT against the housing.
46. Replace and tighten the six 9/64 inch hex head bolts and washers that mate the PMT to the FW housing.
47. Replace and tighten the four 5/32 inch hex bolts with bite washers which fasten the FW housing and PMT to the Brewer chassis.
48. Replace the white face plate covering the foreoptics tube by replacing the two 3/32 inch hex bolts into the Brewer chassis at the spectrometer. Tighten the single 3/32 hex screw on the side of the face plate.
49. Replace the 9 pin connector of the signal line to the PMT by tightening the two flat head screws on the connector.
50. Replace the high voltage cable to the PMT by twisting the BNC connector onto the mate.

51. Replace the FW#3 connector to the FW#3 housing via the two hex head bolts on the ribbon connector.
52. Place the card rack into position inside the instrument, being careful to get all the wires and cables into safe positions.
53. Replace the two 3/32 inch hex head bolts that secure the back card rack feet to the Brewer base. These screws are accessed from underneath the instrument.
54. Replace the two 9/64 inch hex bolts securing the front card rack feet to the Brewer base.
55. Connect all the electronic ribbon cables to the card rack. The connectors should be labeled in black ink corresponding to the board and jumper to which they should connect.
56. Replace the Brewer outer cover and secure the four latches, ensuring that the outer cover is mounted evenly all the way around the Brewer case. Remove the quartz dome protector.
57. Replace the AC power cable and restore power to the Brewer.
58. Initialize communication between the Brewer and the computer.
59. After the motors have initialized and the Home screen is visible, move to the Teletype mode by giving the TT command.
60. Give the command "M,6,0:M,6,256:a". This will rotate FW#3 continually from position 1 to 4 and back. Observe if the FW#3 moves smoothly and does not bind. There should be a rhythm to the rotation that will be interrupted intermittently if there is a binding problem. Abort the command by pressing the "Home" key.
61. If the FW does not seem to be rotating properly it may be necessary to add or subtract some of the nylon washers on the wheel shaft. The housing will have to be disassembled again.
62. Once it is determined that the FW#3 is operating properly a final spectral response calibration should be performed, especially if the NiSO₄ filter was replaced. If the filter was replaced it will be necessary to perform a spectral response temperature dependence calibration of the Brewer as well since the filter has a large temperature dependence of its spectral response.

| Motor # and Name | Step # | Filter | FW Position | Command String |
|-------------------------|---------------|--|--------------------|-----------------------|
| Filter wheel #1 | 320 | 0:film polarizer (horizontal) | O | M,4,320 |
| | 256 | 1:quartz diffuser (translucent) | I | M,4,256 |
| | 192 | 2:blocked aperture (opaque) | II | M,4,192 |
| | 128 | 3:clear aperture | III | M,4,128 |
| | 64 | 4:quartz diffuser; ND of f=2.0 (translucent) | IV | M,4,64 |
| | 0 | 5:film polarizer (vertical) | V | M,4,0 |
| Filter wheel #2 | 0 | 0:f=0 | O | M,5,0 |
| | 64 | 1:f=0.5 | I | M,5,64 |
| | 128 | 2:f=1.0 | II | M,5,128 |
| | 192 | 3:f=1.5 | III | M,5,192 |
| | 256 | 4:f=2.0 | IV | M,5,256 |
| | 320 | 5:f=2.5 | V | M,5,320 |
| Filter wheel #3 | 50 | Clear aperture (transparent) | I | M,6,50 |
| | 114 | Blocked aperture (opaque) | II | M,6,114 |
| | 178 | BG-12 filter | III | M,6,178 |
| | 242 | NiSO4 and UG-11 filter | IV | M,6,242 |

| Filter Wheel | Electronic Board Number | Electronic Board Position (from top of card rack) | Jumper Number |
|---------------------|--------------------------------|--|----------------------|
| #1 | BA E50/B | 2 | 2 |
| #2 | BA E50/B | 2 | 3 |
| #3 | BA E50/D | 3 | 3 |

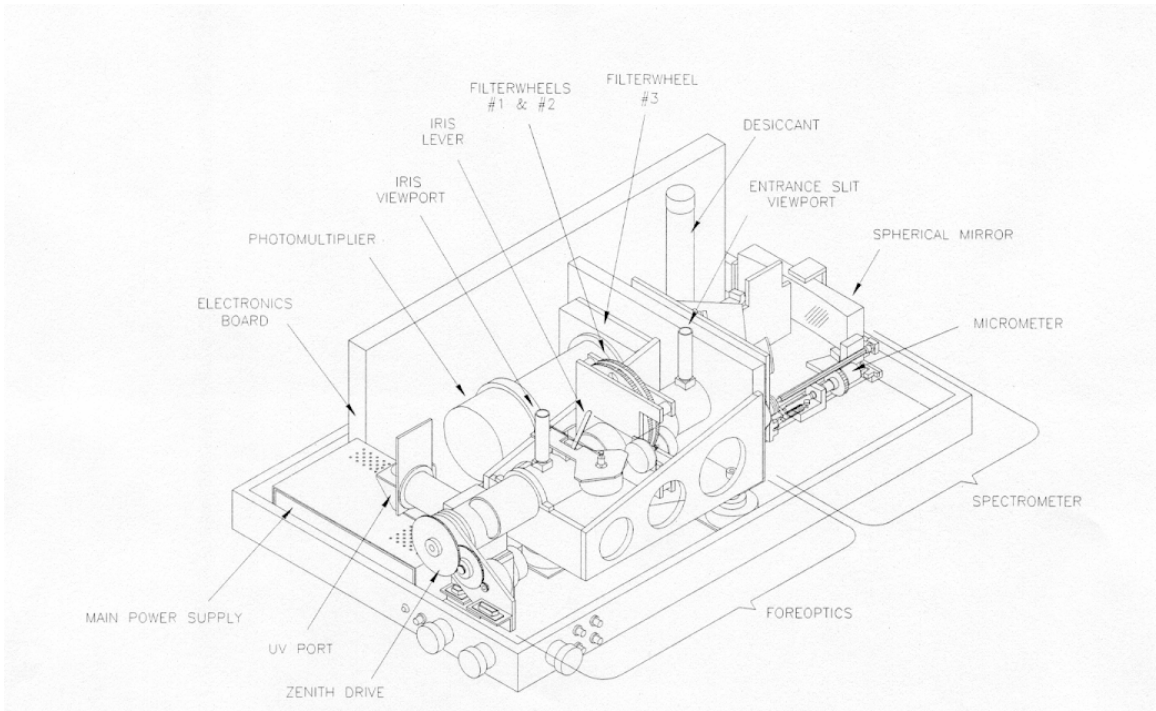

Figure 1: Brewer components